

# IOT-BASED WATER LEVEL MONITORING SYSTEM OF SITU RAWA BESAR

Erna Kusuma Wati<sup>1</sup>, Hari Hadi Santoso<sup>2</sup>, Aryo Laksono<sup>3</sup>

<sup>1,2,3</sup>Department of Engineering Physics, Faculty of Engineering and Science, Universitas Nasional, Indonesia  
e-mail : [ernakusuma.w@gmail.com](mailto:ernakusuma.w@gmail.com)

## Abstract

*Pancoran Mas, Depok city has a water catchment area, namely Situ Rawa Besar. Situ Rawa Besar has the potential to overflow during the rainy season which caused flooding in 2020. The water level of Situ Rawa Besar is not monitored in real time so that information on the increase in water level is late to reach the community. Thus, an IoT-based water level monitoring system using ultrasonic sensors was made so that the community was able to monitor the state of Situ Rawa Besar in real time through a prepared website. In order to use the ultrasonic sensor module, there was a failure to read the water level in previous studies. So in addition to monitoring the water level in Situ Rawa Besar, the purpose of making this system is to prove that ultrasonic sensors can be used in water environments such as situ. System testing was carried out at Situ Rawa Besar and at the Prototype. This system is able to monitor the water level for 24 hours with electrical power provided from batteries integrated with solar panels. Testing was carried out on 6 days with an average water level of 70-72cm (alert level). All height data for 6 days is uploaded to the Thingspeak website and can be seen by anyone. Based on the research on the prototype, the system is able to measure the height from 0-182 cm and turn on the alarm when the height is more than equal to 100 cm.*

**Keywords** : Monitoring, Water Level Measurement, IoT

## 1. Introduction

Depok City, which is a buffer city of DKI Jakarta, has an increasing population every year. The greater the increase in population, the greater the increase in residential areas in the city of Depok. With uncontrolled residential growth, Depok city has become a city with a high risk of disaster. [Beji Subdistrict and Pancoran Mas Subdistrict have flood-prone areas with varying areas. This is caused by climate change, high rainfall, land surface lower than sea level, siltation of rivers, river flow obstructed by garbage, conversion of river area and others. As a result, river flow is obstructed and eventually overflows into settlements. The losses that arise due to flooding are economic losses, clean water difficulties, the spread of disease, casualties, and paralysis of community activities (Ben et.al., 2020).

There is a water catchment area in Pancoran Mas Sub-district as a buffer for river water and rain in the area, namely Situ Rawa Besar. During the rainy season, there is often overflow of water that causes low to high flooding. The community often does not know the process of overflowing water so that the surrounding community suffers material losses. The measuring instrument installed at Situ Rawa Besar is Peilschaal but there is no monitoring post that provides realtime information to the community. Peilschaal is a ruler-shaped tool for measuring river water levels. The data taken will be stored by the Public Works Office and disseminated to residents manually using radio calls (Dewi et.al., 2019).

## 2. Method

This research will be conducted at Situ Rawa Besar from April 2023 to August 2023. in this study there are several testing processes to obtain research results. The author also explains the process based on tables and figures generated from a process or data processing in accordance with the research method formula used in research writing. as for the resulting figures and tables, namely:

## System Design

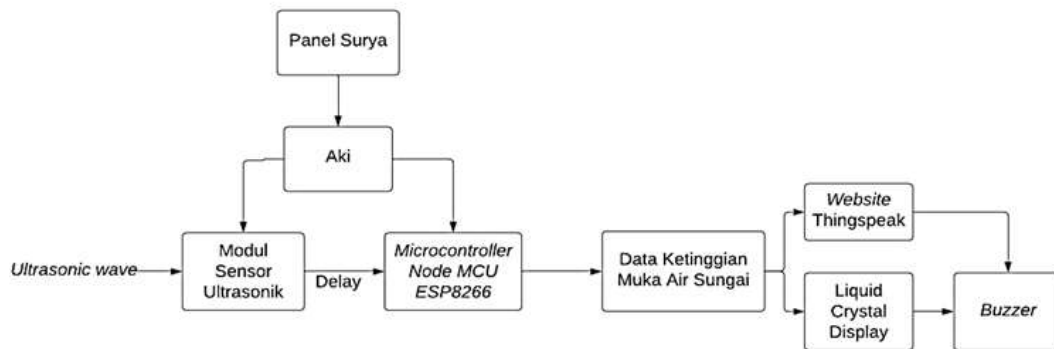

Figure 1. Block Diagram of Water Level Monitoring System  
Source: *Data Processing*

Based on Figure 1, the ultrasonic sensor module gets sound wave input and then provides data to the NodeMCU ESP8266 micro controller in the form of sound wave travel time from the transmitter to the receiver. The input data is processed by NodeMCU ESP8266 into river water level data. The height data is displayed by LCD and Thingspeak website.

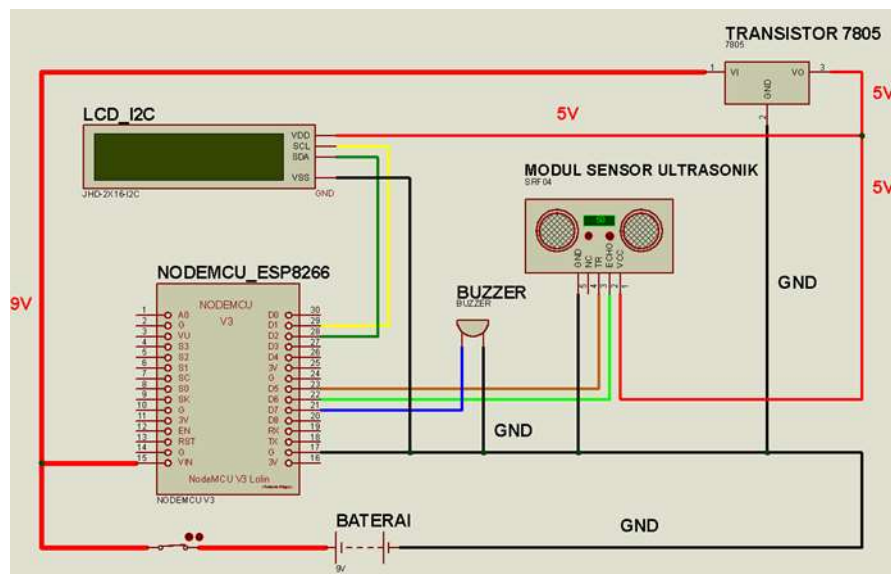

Figure 2. Schematic Diagram of Water Level Monitoring System  
Source: *Data Processing*

Figure 2 is a schematic diagram of the river water level monitoring system that will be made. The sensor components, LCD, resistors are connected to the NodeMCU ESP8266 module pin which aims to provide the desired program. ESP 8266 has an output voltage of 12 Volts. Because the components require a voltage input of only 5 volts, a 7805 transistor is needed to reduce the voltage from 12 volts to 5 volts. The use of LCD aims to see the messages given by the system regarding onsite water conditions. It will be connected online to the Thingspeak website to monitor the water condition. In addition to being displayed on the LCD, messages will be uploaded on the Twitter platform so that people are aware of the current conditions. ESP 8266 programming will be done in the Arduino IDE software, namely to initiate data reading, sending data to the website, providing messages to the LCD.

Table 1. Block Diagram of Water Level Monitoring System (Dewi et.al., 2019).

Device Name	Device Pins	Pin	NodeMCU ESP8266
Sensor Module Ultrasonic SRF05	VCC	VIN	
	TRIG	D6	
	ECHO	D5	
	OUT	Not Connected	
Buzzer	GND	G	
	+	D7	
I2C LCD	-	G	
	VCC	Vin	
	GND	G	
	SDA	D1	
Switch	SCL	D2	
	Switch Pins	Vin	

Source: Data Processing

Table 1 is the pin allocation of electronic devices connected to the NodeMCU ESP8266. This relates to the program created in the Arduino IDE as output or input.

### Testing Grounds



Figure 3. Testing ground  
Source: Data Processing

Figure 3 is a visualization of the testing site for the water level monitoring system. Situ Rawa Besar is located in Depok Jaya urban village, Pancoran Mas sub-district, Depok city, which is one of the water catchment areas in Depok city. The water flow of Situ Rawa Besar comes from the Ciliwung river and Pasanggrahan river. The reason for choosing this place is based on the floods that have occurred several times in the Situ Rawa Besar area. Local residents are not aware of the overflowing water, causing both material and physical losses.

## System Output Conditioning Based on Altitude

Table 2. System Output Conditioning

NO	Level(cm)	Display	Component Activation Buzzer
1	$h \geq 130$	DANGER	ON
2	$100 \leq h < 130$	STAY AWAY	ON
3	$70 \leq h < 100$	WASPAD A	OFF
4	$h < 70$	NORMAL	OFF

Source: Data Processing

Table 2 is an overview of the conditions that will be tested in this study. There are 4 variations of data that will be tested with conditions of Danger, Alert, Normal. Danger condition is where the water overflows to more than or equal to 130 cm. Alert is a condition where the water has overflowed 100 cm but less than 130 cm, Alert is a condition where the water overflows to more than or equal to 70 cm but less than 100 cm and normal is a condition where the water is not overflowing or less than 70 cm.

## Thingspeak

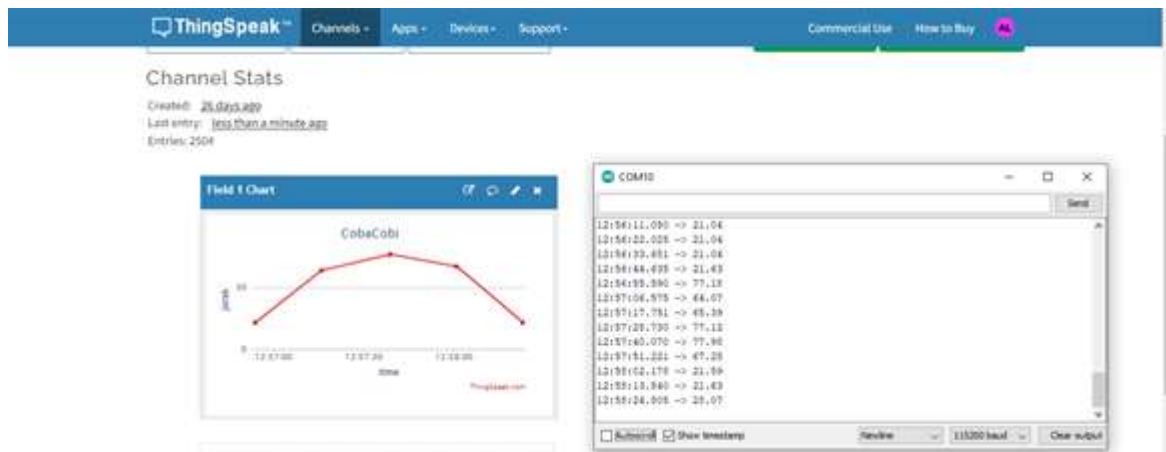

Figure 4. Thingspeak website  
Source: Data Processing

Figure 4 shows the display of the Thingspeak website after getting the ultrasonic sensor data transfer from the NodeMCU ESP8266. Sensor output on the Arduino IDE serial monitor displays data every 5 seconds. While the thingspeak website displays data every 15 seconds. This is due to the length of data transmission from Arduino IDE to thingspeak which depends on the internet network. So that if the sensor output data transmission time from Arduino IDE to Thingspeak is longer than the delay set on the Arduino IDE, the data provided is the latest data from the ultrasonic sensor output and skips the previous data.

### 3. Results and Discussion Tool Testing



(a)



(b)

Figure 5. Testing and storage of tools (a) Peilschaal listed on the Situ Rawa Besar sluice gate (b) Elevation where tools are stored

Source: *Data Processing*

Figure 5 (a) is a visualization of the peilschaal stored at the sluice gate of a large swamp site. The maximum height of the installed peilschaal needs to be defined. Where the highest scale is 180 cm with a difference of 10 cm and the line between the upper and lower scale is 5 pieces. then calculated with the equation:

So the smallest measurement scale value (SPT) obtained from equation 2.4 is 2 cm. In addition, the maximum height of the peilschaal is shown on 1 line above 180cm. If calculated by equation (4):

$$h_{max} = s_{max} + (n \times SPT) \quad (4)$$

Where:

$h_{max}$  = maximum height of peilschaal (cm)

n = number of lines

The maximum height of the peilschaal is therefore 182 cm.

Figure 5 (b) is where the river water level monitoring device is stored. The tool is stored at the maximum height ( $h_{max}$ ) of the installed peilschaal, with the aim of calculating the water level to the maximum height of the peilschaal. The water level measurement using the ultrasonic sensor module is formulated as follows:

$$h = h_{max} - \left(\frac{t \times v}{2}\right) \quad (5)$$

Where:

h = water level (cm)

$h_{max}$  = stored tool height (cm)

t = time for the sound wave to reach the receiver ( $\mu$ sekon)

v = speed of sound (cm/ $\mu$ sekon)

Equation 5 is needed to measure the water level in Situ Rawa Besar

### Characteristics of HYSRF 05 Ultrasonic Sensor

Table 3. HY SRF05 Ultrasonic Sensor Characterization Testing Results

Reference(X)	Ultrasonic(Y)	Regression Equation
5	4.98	$Y = 1.01X - 0.05$ Standard Error = 0.32
10	10.07	
20	20.12	
30	30.02	
40	39.47	
50	49.46	
60	59.17	
70	69.95	
80	79.65	
90	88.97	
100	99.67	

Source: Data Processing

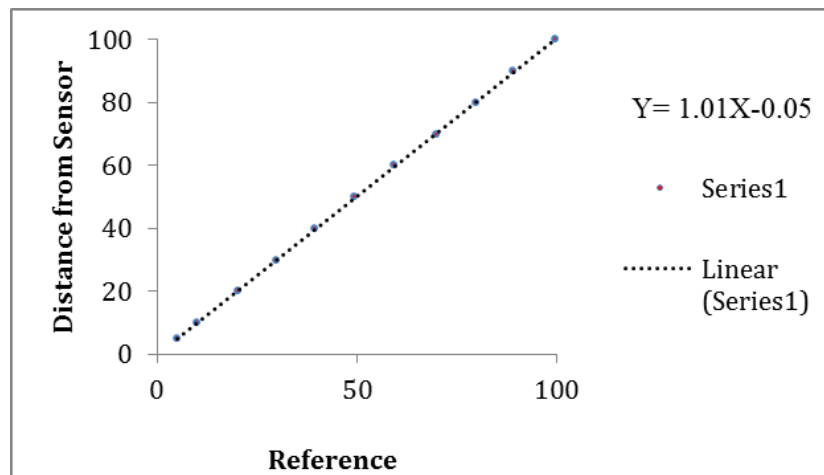

Figure 6. Characterization Chart of HY SRF 05 Ultrasonic Sensor Module  
Source: Data Processing

Figure 6 shows the characterization of the ultrasonic sensor module. After the reference value and measurement value of the ultrasonic sensor are analyzed using linear regression, the following formula is obtained:

$$Y = 1.01X - 0.05 \quad (6)$$

Where:

Y = Ultrasonic sensor output value

X = Reference value

In addition, based on Table 3 the resulting standard error is 0.32. This value is very good because the distance measured by the ultrasonic sensor module does not deviate significantly from the distance measured by the ruler as a reference.

### Monitoring Results at Situ Rawa Besar

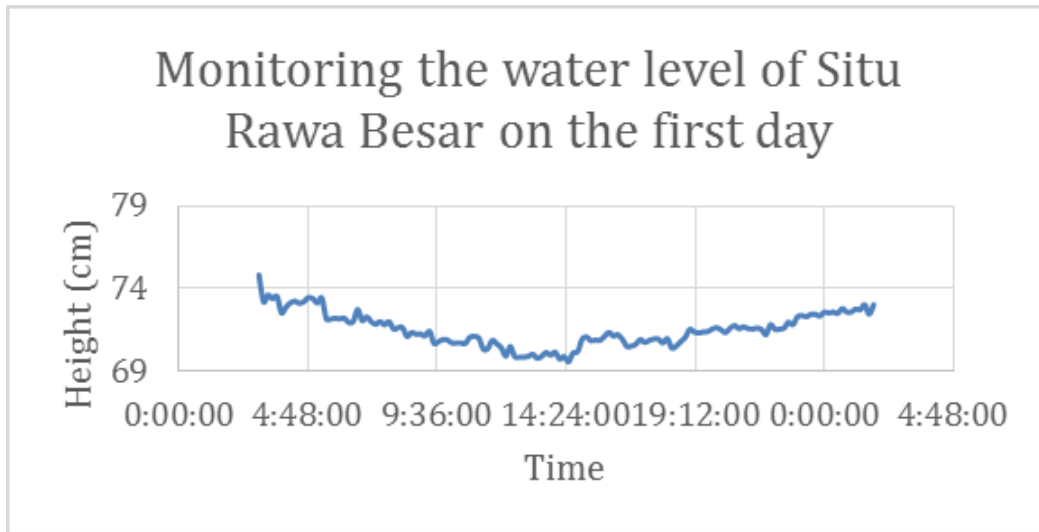

Figure 7. Water Level Monitoring Results of Situ Rawa Besar on the First Day  
Source: Data Processing

Figure 7 is the result of the first day of monitoring starting on Monday at 03:00 until Tuesday at 02:59 (24 hours). The y-axis is the water level in centimeters and the x-axis is the test time. There was a decrease and increase in the water level of Situ Rawa Besar during the test. The maximum water level occurred at 03:10 where the water level was 74 cm, while the minimum water level occurred at 14:30 where the water level was 69.5 cm. As for the test at 03.00 to 14.30, the water level decreased from 74-69.5 cm while at 14.31 to 02.59 the water height increased from 69.5 - 73 cm.

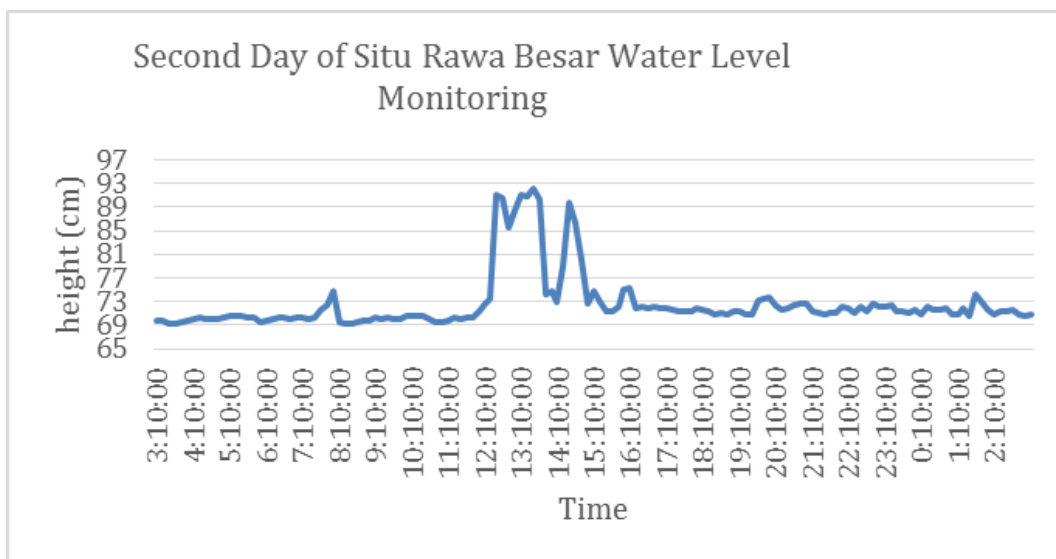

Figure 8. Water Level Monitoring Results of Situ Rawa Besar on the Second Day  
Source: Data Processing

Figure 8 is the result of the second day of monitoring starting on Tuesday at 03:00 until Wednesday 02:59 (24 hours). There are some differences with the monitoring results on the first day. In contrast to the first day, the water level tended to stabilize at 70 cm from 03:00 to 11:00 with a measurement deviation at 08:10 when the water level was detected at 75 cm.

This event may have occurred due to the deviation of the direction of propagation of the sound waves coming out of the ultrasonic sensor so that it touches the wall. The direction of propagation of sound waves coming out of the ultrasonic sensor is visualized in Figure 4.5.

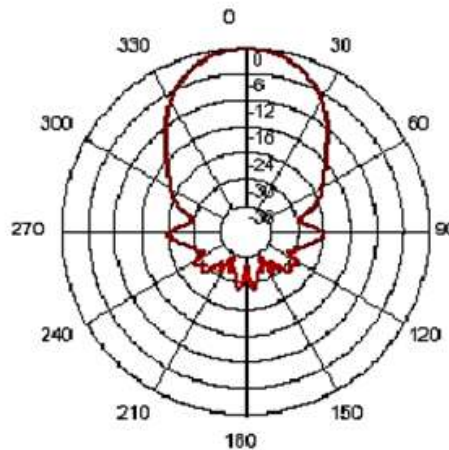

Figure 9. Visualization of the Direction of Sound Wave Propagation from the HYSRF 05 Ultrasonic Sensor

Source: Data Processing

Figure 9 is a visualization of the sound wave propagation distribution of the HY SRF05 ultrasonic sensor. This is what makes the height of the ultrasonic sensor change every time because the propagation is not only straight at 0 degrees but can deviate up to 30 degrees.

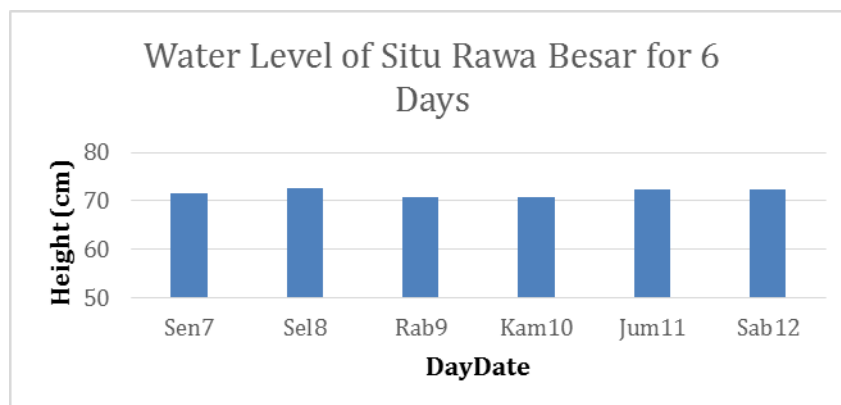

Figure 10 Water Level Monitoring Results of Situ Rawa Besar for 6 Days  
Source: Data Processing

Figure 10 shows the average daily water level of Situ Rawa Besar during the 6 days of monitoring. The maximum level was reached on Tuesday with an average level of 72.5 cm while the minimum level was reached on Thursday with an average level of 70.7 cm. The water level so far is in a state of alert and the difference in height per day does not change significantly, because the environmental conditions around Situ Rawa Besar were tested in August, which has entered the dry season. So the weather for 6 days is sunny.

## Monitoring System

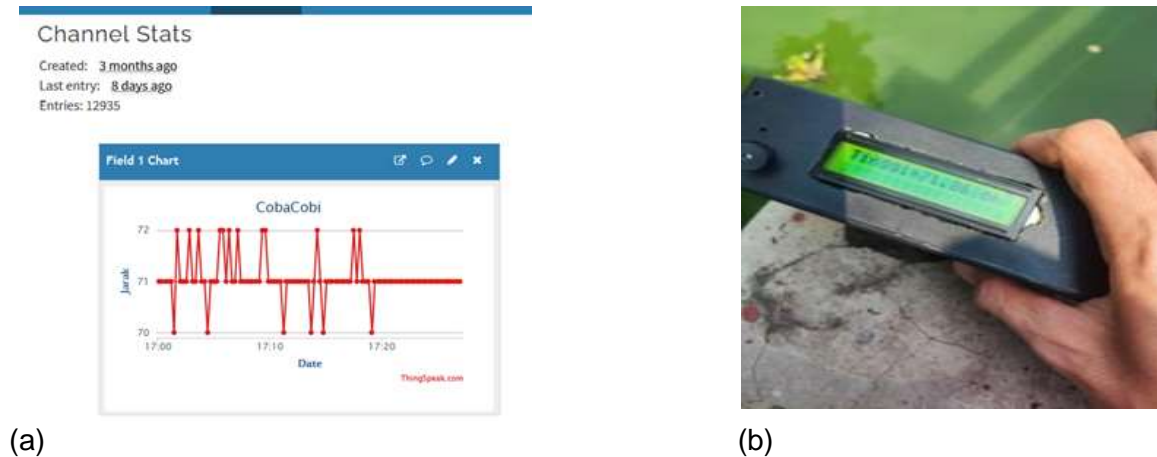

Figure 11. Water Level Monitoring Data Display (a) Thingspeak Display Testing Tool at Situ Rawa Besar (b) LCD Display

Source: Data Processing

Figure 11 (a) shows the data uploaded to the Thingspeak website. The data display is a graph between altitude and time. The latest data uploaded is 100 data. This data can be viewed publicly at the url: <https://thingspeak.com/channels/2151625>. For observers or account holders, data can be downloaded by clicking export. The export results are loaded in the form of an excel file.

The data uploaded on the Thingspeak website is the water level for 24 hours with a delay of 10-15 seconds. The amount of delay is influenced by the program uploaded to the MCU Node and the connected internet connection.

Based on the uploaded program (seventh attachment) to the NodeMCU ESP 8266, the data upload delay is 1 second, but the data uploaded to Thingspeak is every 10 to 15 seconds. This is because the Thingspeak website only uploads sampling data from 10 to 15 altitude data obtained by the ESP8266 MCU Node in 10-15 seconds. Figure 4.9 (b) shows the LCD display for manual observation. What the LCD displays is the water level data in cm and the condition of the level whether it is danger, alert, caution, or normal.

## Testing with Prototypes

The testing with the prototype is done to find out whether the conditioning in Table 2 can be fulfilled by the system made. The prototype used is an aquarium measuring 60x40x34cm. it is known that the maximum height of the aquarium is 34cm so that to measure the water level in it is:

$$h_a = h_{max1} - \left(\frac{t \times v}{2}\right) \quad (7)$$

Where:

$h_a$  = prototype yield height (cm)

$h_{max1}$  = height of the tool stored in the prototype (cm)

However, the conditioning of Table 2 requires measurements in the range 0-182, so to get this range, it is necessary to add a variable to the calculation of equation 7, namely :

$$h_a = \left(h_1 - \left(\frac{t \times v}{2}\right)\right) \times \frac{h}{h_{max1}} \quad (8)$$

Where:

$h_s$  = simulated water level (cm)

$h$  = maximum height of peilschaal (cm)

$h_{max1}$  = maximum height of the prototype (cm)

Equation 8 is needed to program the NodeMCU to measure the water level. The results can be seen in Figure 12 below.

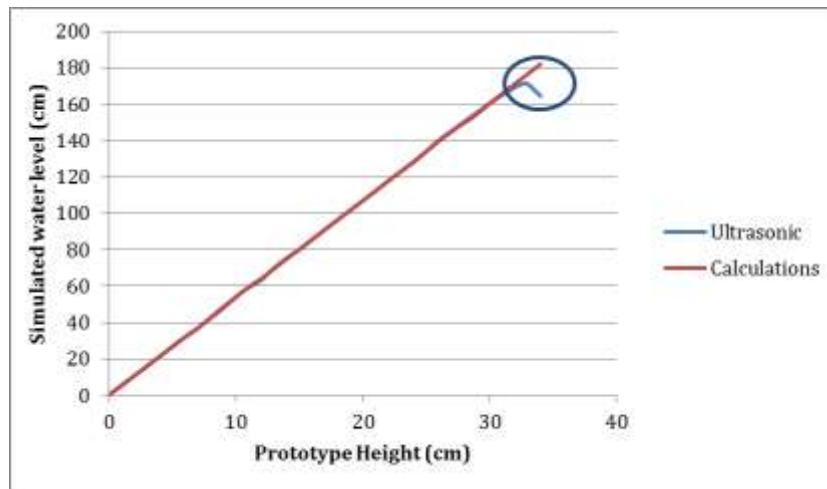

Figure 12. Height Testing Results with 60x30x34cm Prototype  
Source: *Data Processing*

Based on the test results (Figure 4.10), the sensor reading value has a large deviation at a height of 33 cm in the prototype or 176 cm in the simulation. This is due to the measurement principle used in this system, which is the maximum distance minus the sensor reading. Therefore, when the sensor reading approaches the lower limit of its measurement range of 2 cm, the measurement error increases significantly. However, this measurement is a simulation to carry out monitoring with several conditions set and using a prototype whose height is 5.3:1 with the height of the Situ Rawa Besar river.

Table 4. LCD display test on the water level monitoring device test

No	Height (cm) Ultrasonic	Reference	LCD Display	Conditioning
1	0.4	0		
2	18.2	18.2		
3	28.6	28.2		
4	33.4	33.7		
5	36.8	37	NORMAL	h<70
6	48.6	48		
7	57.8	58		
8	63.4	64.2		
9	68.8	68.5		
10	75	74.4		
11	81.2	81.3	Alert	70≤h<100
12	91	91		
13	100.2	100		
14	110.6	110.8	Alert	100≤h<130
15	120	119.9		
16	129.2	129.5		
17	140.2	139.7		
18	147.8	147.5		
19	154	153		
20	163.2	163.8	Danger	h≥130
21	169.7	171.8		
22	171	173.9		
23	171	176.6		
24	164.4	182		

Source: *Data Processing*

LCD display of the height and condition of the water level. At a height of less than 70 cm, the LCD displays the word "Normal"; at a height of 70 cm to 100 cm, the LCD displays "Alert"; at a height of 100 to 130 cm, the LCD displays "Alert"; at a height of 130 cm to 182 cm, the LCD displays "Danger". This display is in accordance with the program made based on Table 2.

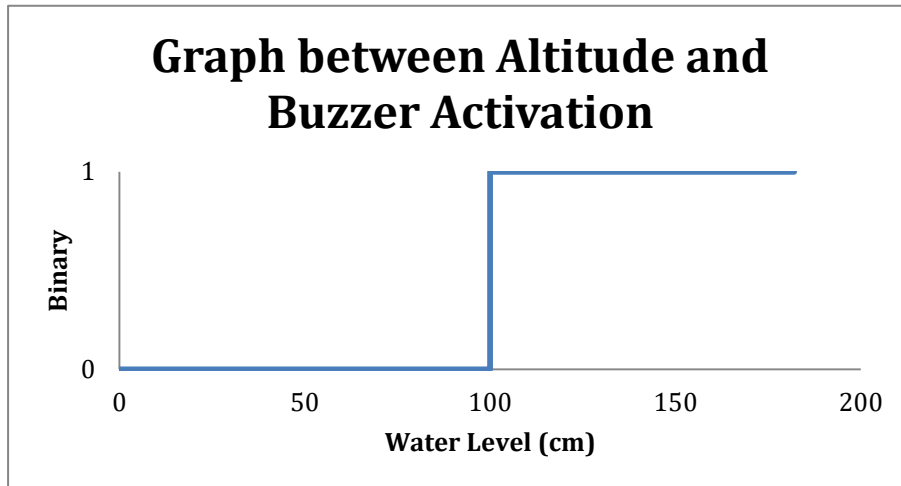

Figure 13. Buzzer activation testing in the height state from 0-182 cm  
Source: *Data Processing*

Figure 13 is a test of *buzzer* activation against the water level. *Buzzer* activation is given by D7 NodeMCU which is a digital pin. So that *on* and *off* are initialized with numbers 1 and 0. At heights of 0 to 99 cm the buzzer is off, while at heights of 100-182 the buzzer is on. These results are in accordance with the desired conditioning as listed in Table 2.

### Battery Testing

Table 5. Battery Consumption and Endurance

Battery Type	Maximum Voltage	Length of time
ABC Battery	9V	0.5 hours
Battery	14.4 V	60 Hours

Source: *Data Processing*

Based on Table 5, the batteries tested in the large swamp situ water level monitoring system are 9V batteries and accumulators with a maximum voltage of 14.4 V. The 9 Volt battery is able to provide voltage to the system for 30 minutes while the accumulator is able to provide voltage to the system for 60 hours.

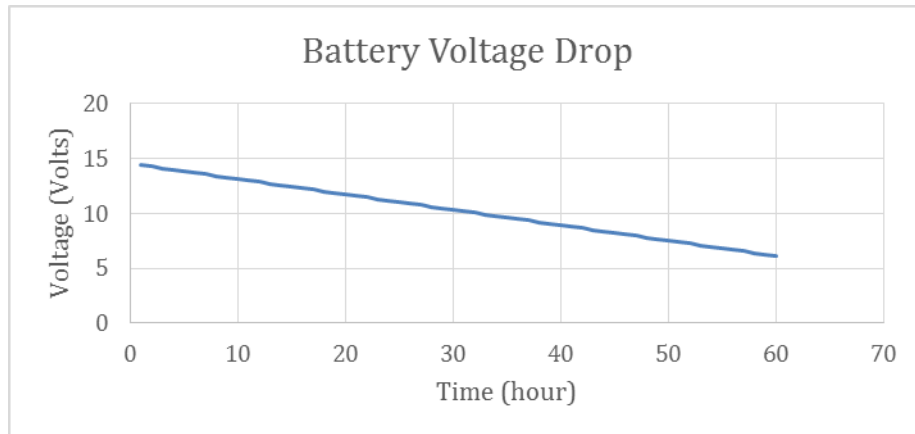

Figure 14. Battery voltage drop graph  
Source: *Data Processing*

Figure 16 shows the voltage drop of the battery from 14.4 volts to 6 volts. The time taken is 60 hours with an average voltage drop of 0.14 volts/hour. There is no significant drop because the system does not activate the buzzer component. At a voltage of 6 volts, the system does not work optimally. This is because the voltage given to the LCD component and the ultrasonic sensor module is divided by the 7805 transistor with a ratio of 0.3125. Voltage 6 volts, the voltage received by the two components is only 2 volts. The minimum voltage that can activate the LCD and ultrasonic module optimally is 3 volts. So if the voltage received is less than 3 volts then these components do not work optimally.

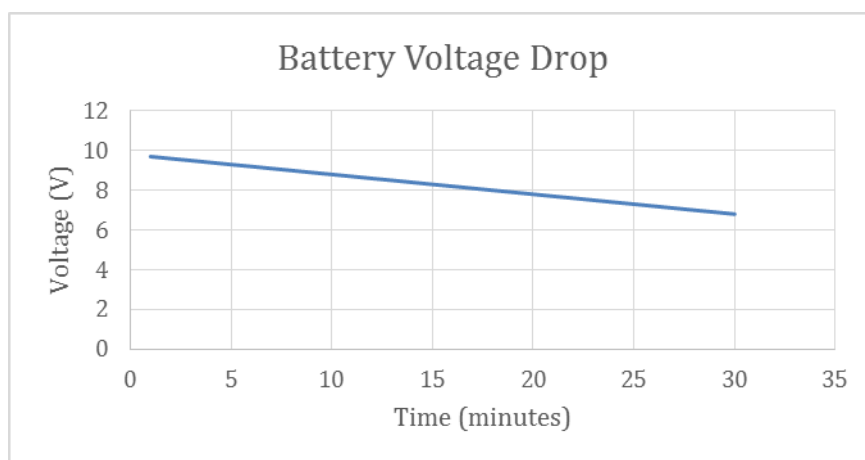

Figure 15. 9 Volt ABC Battery Voltage Drop  
Source: *Data Processing*

Figure 15 is a graph of the battery voltage drop against time in minutes. The battery voltage drop from 9 volts to 6.8 volts takes 30 minutes. Thus, the average voltage drop is 0.1 volt/minute. The difference in voltage supply specifications makes the battery consumption more wasteful compared to the accumulator. Among them, the electric power owned by the accumulator is 84 wp rechargeable while the abc battery is 3.6 wp un-rechargeable. For water level monitoring needs, the system requires a continuous voltage supply for 24 hours. So it requires a supply that can be recharged with electric power such as accumulators and integrated with solar panels as a charger.

#### 4. Conclusion

A river water level monitoring system with an ultrasonic sensor module has been successfully made that can be carried out in a river environment for 24 hours with a more

optimal voltage supply using a battery. Measurement data is successfully uploaded to the Thingspeak website which can be seen by everyone as an application of IoT in a river water level monitoring system using an ultrasonic sensor module based on the Internet of Things. The ultrasonic sensor is proven to be able to measure the water level in the water environment (Situ Rawa Besar) from 0-182 cm with a standard error from testing the ultrasonic sensor characteristics of 0.32. The water level measurement data is uploaded to the Thingspeak website every 10-15 seconds. The data displayed on the website is the latest 100 data.

## References

- Ben, A., Adly, E., & Hasannah, D. 2020. *Internet Of Things (Iot) Light Control System Using a Mobile-Based Raspberry Pi*. IAIC Transactions on Sustainable Digital Innovation (ITSDI), 2(1), 46-53.
- Dewi, N. H. L., Rohmah, M. F., & Zahara, S. 2019. Smart Home Prototype With Internet Of Things (IOT) Based NODEMCU ESP8266 Module.
- Diriyana, A., Darusalam, U., & Natasha, N. D. 2019. Water Level Monitoring and Flood Early Warning Using Microcontroller With IoT Based Ultrasonic Sensor. *Jurnal Teknik Informatika CIT Medicom*.
- Djalilov, A., Sobirov, E., Nazarov, O., Urolov, S., & Gayipov, I. 2023, March. Study on automatic water level detection process using ultrasonic sensor. In IOP Conference Series: Earth and Environmental Science (Vol. 1142, No. 1, p. 012020). IOP Publishing.
- Dondang, R. A., Mansor, Z., & Satrya, G. B. 2021. Design and Development of Flood Monitoring and Early Warning System. *Malaysian Journal of Science and Advanced Technology*, 72-76.
- Fitriyah, H., & Setyawan, GE (nd). Monitoring System Using Blynk and Controlling Mushroom Plant Watering With Fuzzy Logic Method.
- Khaery, M., Gunawan, A. A. N., & Paramarta, I. B. A. 2020. Water flow control system by online based on ATmega328P microcontroller. *Contemporary Engineering Sciences*, 13(1), 303-314.
- Perumal, T., Sulaiman, M. N., & Leong, C. Y. 2015. Internet of Things (IoT) enabled water monitoring system. In 2015 IEEE 4th Global Conference on Consumer Electronics (GCCE) (pp. 86-87). IEEE.
- Sunkpho, J., & Ootamakorn, C. 2011. Real-time flood monitoring and warning system. Songklanakarin. *Journal of Science & Technology*, 33(2).
- Taylor, C. J., & Alley, W. M. 2001. Ground-water-level monitoring and the importance of long-term water-level data (Vol. 1217). Denver, CO, USA: US Geological Survey.